

DRV-400/500/630

Single Stage, Oil Re-circulating, Air Cooled, and Direct Driven



- 간결한 디자인
- 신뢰성 및 내구성
- 손쉬운 정비 및 운전
- 간단한 설치 / 공냉식 (냉각수 불필요)
- 직구동 방식 / C face 형 설계 / 벨트 불필요
- 내부 취부형 배기 필터 / 99% 오일 free 배기
- 조용한 운전

표준 품목 : Composite Vane , 철망형 흡입구 필터 스크린, 진동흡수발판, TEFC 고효율 모터, Anti-Suck back 밸브, 유면계, Gas Ballast Valve, Spin-on Oil Filter



선택 품목 : 배기 압력 게이지, Oil Level Switch (Port), Temperature Switch (Port), Heater, Water Cooler, and Float Valve Assembly for oil return

Technical data

Models		DRV-	400	500	630
Displacement	60Hz	m ³ /h	505	-	780
		ℓ/min	8,420	-	13,000
	50Hz	m ³ /h	420	600	660
		ℓ/min	7,000	10,000	11,000
End-Vacuum	F or N Type	mbar	0.1	0.1	0.1
	L Type		10	10	10
Motor (3Ph)	60Hz	kW(IEC)	11.25	15	18.5
		HP	15	20	25
	50Hz	kW(IEC)	15	11.25	15
Revolution	60Hz	RPM	1,160	1,160	1,160
	50Hz		980	980	980
Noise	60Hz	dB(A)	78	79	79
	50Hz		76	77	77
Operating Temp.		°C	80	82	80
Oil Capacity		Ltr	19	19	19
Connections	Intake	G(BSP) or NPT	3"	3"	3"
	Exhaust		3"	3"	3"
Weight	with motor	kg	504	544	703

Performance Curve

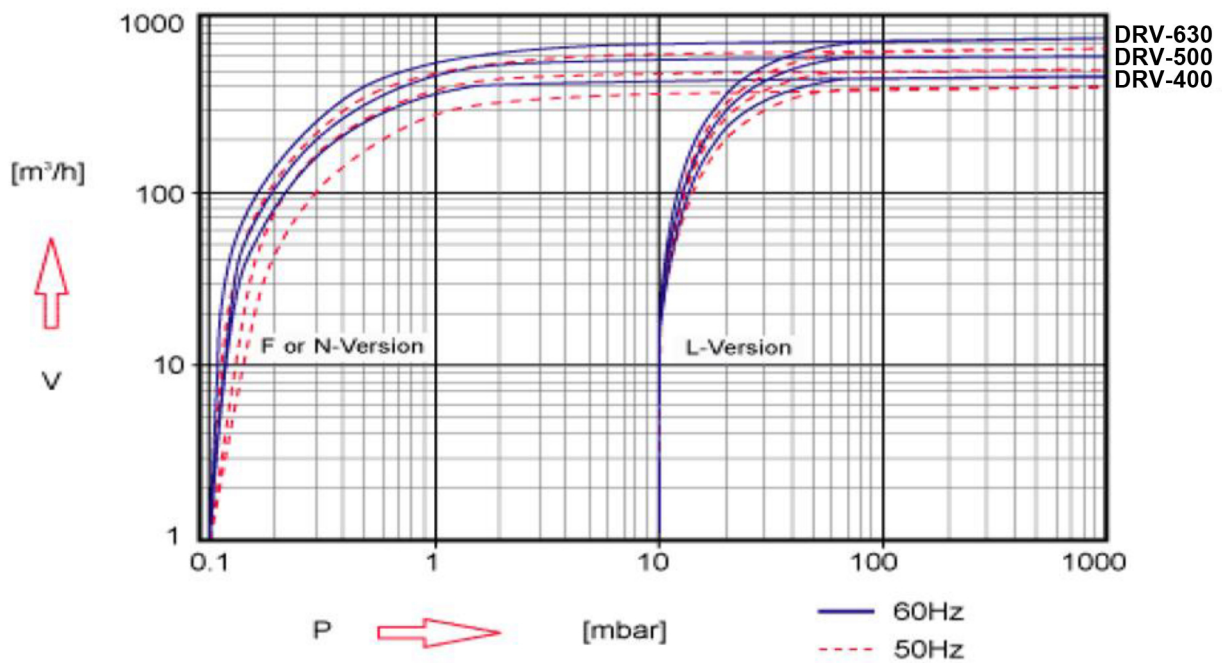

Dimensions

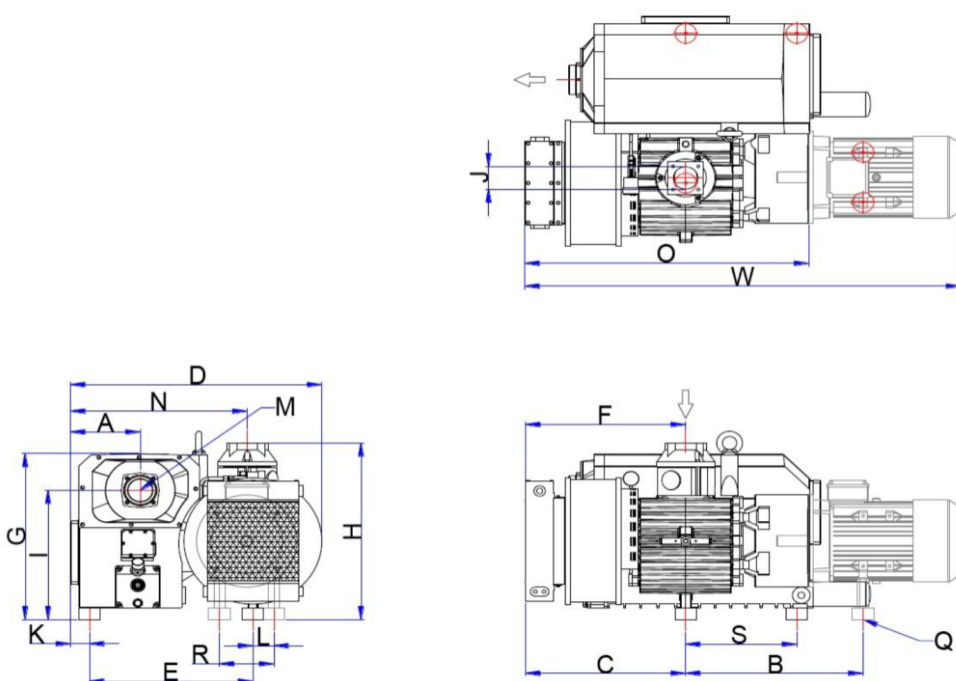

Model	W	D	H	A	B	C	E	F	G	I	J/M	K	L	N	O	Q	R	S
DRV-400	1484	874	671	242	417	494	569	494	631	491	G3"	65	118	614	889	4×M12	279	387
DRV-500	1583	874	671	242	549	559	569	559	631	491	G3"	65	118	614	988	4×M12	279	387
DRV-630	1747	874	671	242	636	595	569	595	631	491	G3"	65	138	614	1097	4×M12	318	387